

GEARHEAD

CONNECTION DIAGRAMS

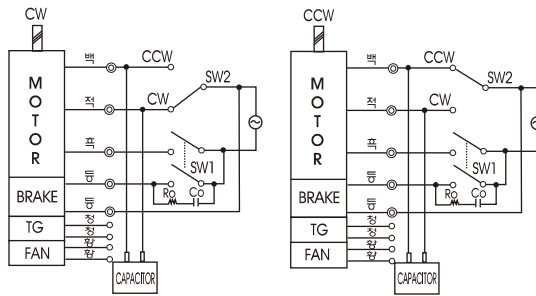

※회전방향은 출력축에서 볼경우

DIMENSIONS

K9P□BU



K9P□BUF



DECIMAL GEARHEAD
K9P10BX

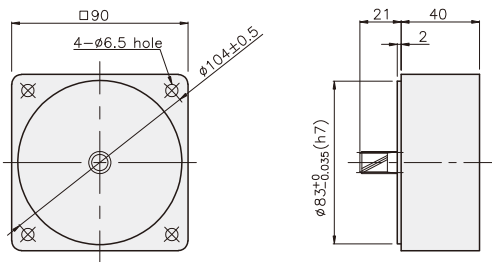

KEY SPEC

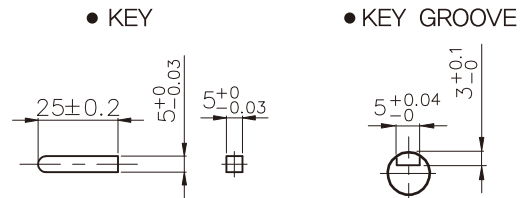

GEARHEAD

K9P□BU

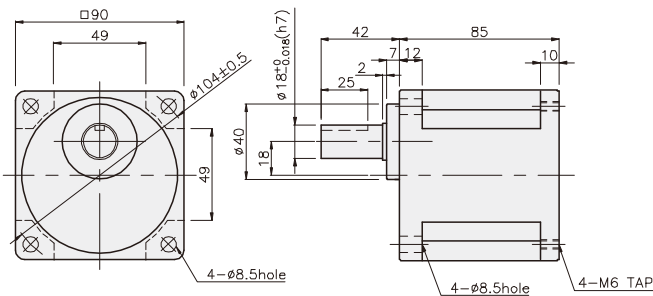

K9P□BUF

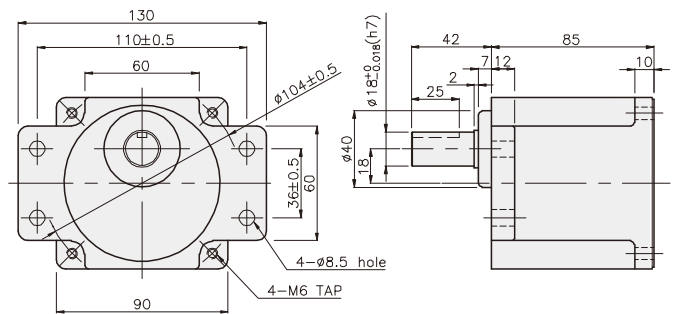

GEARHEAD

DIMENSIONS

K9RP180F□-D + K9P□BU

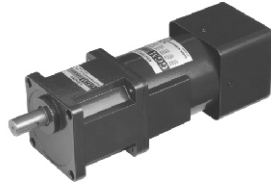

K9RP180F□-D + K9P□BUF



무게

PART	WEIGHT(kg)
MOTOR	4.70
DECIMAL GEARHEAD	0.62

치수도표

품번	적용기종	취부 BOLT
01	K9P3~200BU	M6 P1,0 X 20
02	K9P10BX	M6 P1,0 X 65

무게

PART	WEIGHT(kg)
K9P3~10BU	1.44
K9P12.5~20BU	1.55
K9P25~60BU	1.69
K9P75~200BU	1.74

치수도표

품번	적용기종	취부 BOLT
01	K9P3~200BUF	M6 P1,0 X 20
02	K9P10BX	M6 P1,0 X 65

무게

PART	WEIGHT(kg)
K9P3~10BUF	1.50
K9P12.5~20BUF	1.62
K9P25~60BUF	1.76
K9P75~200BUF	1.82

K9RP180F□-D + K9P□BU

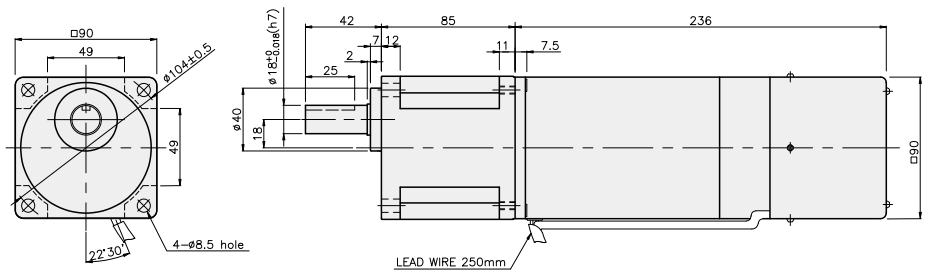

K9RP180F□-D + K9P□BUF

